

Three-speed rotary circulator pumps are suitable for circulating water in devices.



## Construction characteristic

- cast iron pump body
- technopolymer impeller
- stainless steel guide ring
- chrome steel shaft
- stator body made of aluminum
- axial bearing of ceramic/carbon
- radial bearing made of nickel-plated steel

## Motor

- wet rotor
- asynchronous single phase
- 3-speed run
- built-in capacitor
- insulation class F
- degree of protection IP 54

## Usage

- clean, non-aggressive and non-explosive liquids
- without solid particles and fibers
- liquid temperature: from + 10°C to + 110°C
- max. operating temperature 40°C
- max. operating pressure 10 bar
- the pump must be installed so that the motor shaft is in the horizontal position
- connection: thread

## Aplikace

- heating, pressure or open tank systems installed in buildings or industrial systems

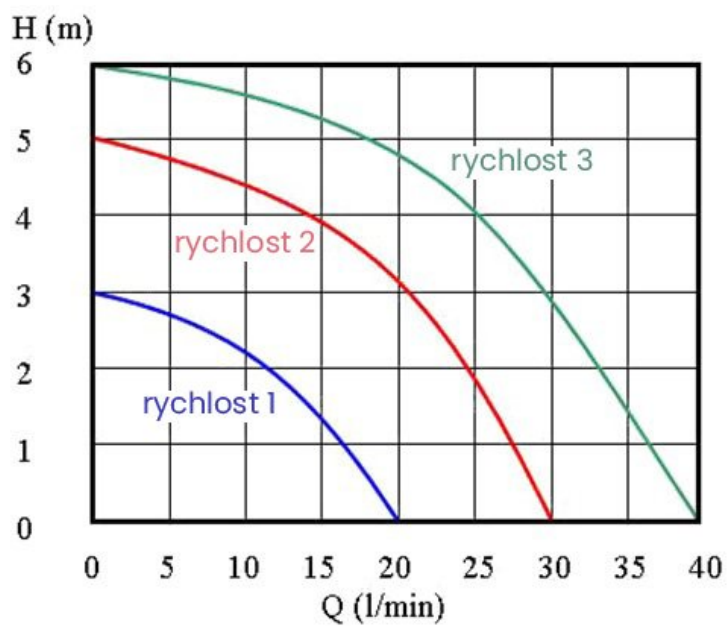

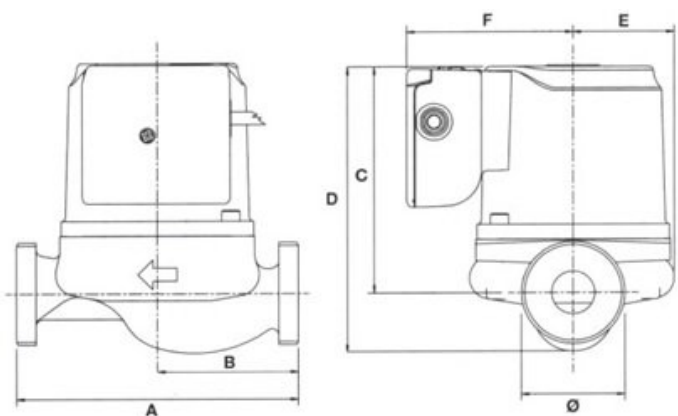

<b>Type:</b>	25-40 180 mm
<b>Power input:</b>	90 W
<b>Q max:</b>	2400 l/h
<b>Head height:</b>	6 m
<b>Voltage:</b>	230 V
<b>Weight:</b>	3,2 kg
<b>A dimensions:</b>	180 mm
<b>B dimensions:</b>	90 mm
<b>C dimensions:</b>	105,4 mm
<b>D dimensions:</b>	135 mm
<b>E dimensions:</b>	46,6 mm
<b>F dimensions:</b>	76,7 mm
<b>Max. temperature:</b>	110 °C
<b>Inlet connection:</b>	6/4"
<b>Build in dimension:</b>	180 mm
<b>Max. pressure:</b>	10 bar