

Intelligent pumps - boostersets with control unit, integrated real-time LCD led display. Simple adjustment and control, dry running monitoring - automatic restart after water source recovery (pumping tests of dry running). Pipe leakage protection function. All fitted with a self-priming pump with a washable 80 µm mechanical impurities pre-filter, supplied with a filter maintenance key.

NOVINKA
2024



Construction characteristic

- built-in intelligent control unit
- stainless steel pump housing

Motor

- closed, cooled from the outside
- IP 44 protection
- insulation class F
- single phase version with permanently built-in condenser
- thermal protection in the motor winding
- flexicable 1,5 m

Usage

- fluid type: clean water without solids and abrasive material
- max. pumped liquid temperature 40°C
- max. recommended suction height with non-return valve 8 m
- max. working pressure 10 bar

Aplikace

- family houses, cottages, cottages
- irrigation

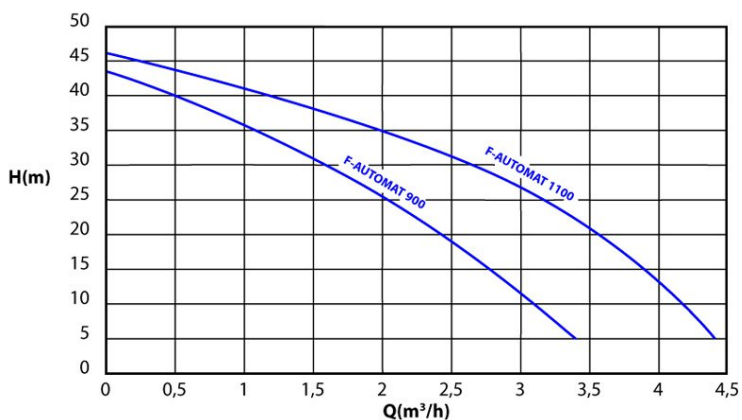

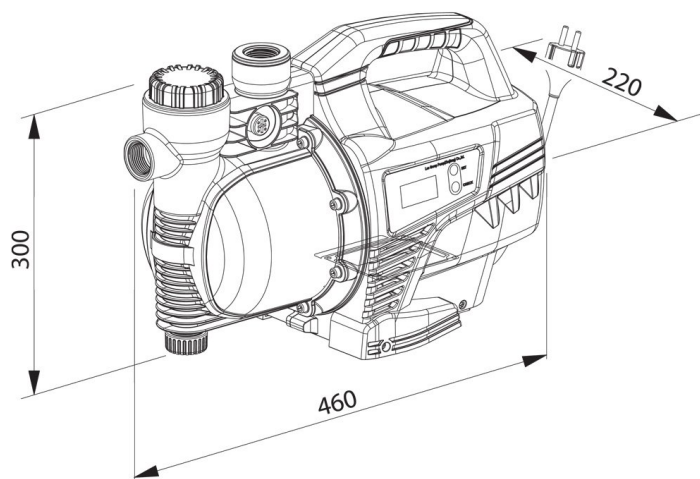

Type:	1100
Power input:	1100 W
Q max:	l/h
Head high:	45 m
Voltage:	230 V
Weight:	13 kg
Suction height:	8 m

