

Automatic transfer pump for sewage and waste water, equipped with two BESTINOX 1500 pumps equipped with double-seal.



Construction characteristic

- polyethylene stainless steel anti-corrosion tank 750 l
- plastic lid with thread for easy access to the pump
- simple dismantling of the pump from the box
- the box is fully equipped including electric wiring

Usage

- waste liquids for household and industry
- pumping waste water and rainwater
- max. operating temperature 40°C

Pump BESTINOX 1500

- degree of protection IP 68
- insulation class B
- single phase version with 2 built-in condensers
- thermal protection in the motor winding
- speed 2850 rpm
- flexicable 10 m H07RNF
- version with float switch
- pump body of stainless steel AISI 304
- stainless steel impeller AISI 304
- Stainless steel shaft
- special double mechanical seal ceramic/carbon, silicon/silicon
- handle and suction body of stainless steel AISI 304

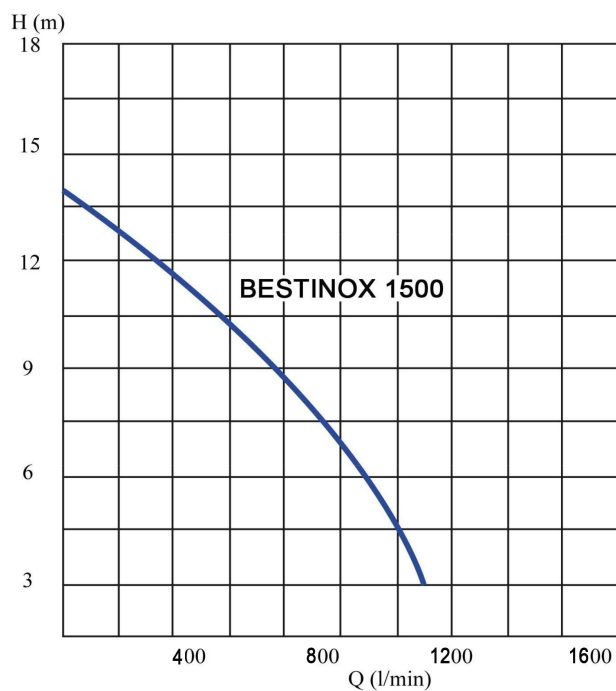

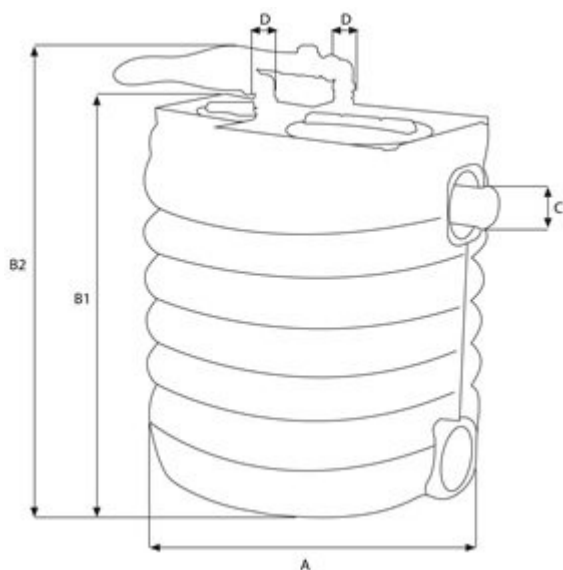

Type:	SUMOBX 750/Best Inox 1500-2
Power input:	1500 W
Q max:	60000 l/h
Head high:	14.5 m
Voltage:	230 V
Cable length:	10 m
A dimensions:	1100 mm
B dimensions:	1350 mm
B1 dimensions:	1160 mm
C dimensions:	110 mm
D dimensions:	63 mm
Connection:	2"
Max. temperature:	40 °C
Tank volume:	750 l

