

Boostersets with a multistage pump suitable for pumping clean water without solid admixtures.

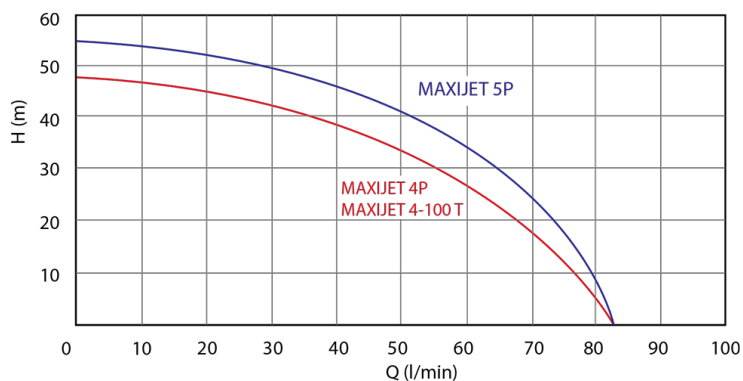

Construction characteristic

- stainless steel pump body
- suction and discharge parts made of cast iron
- distributor wheels made of technopolymer
- impellers from technopolymer
- Stainless steel shaft
- a mechanical seal made of graphite and a counterflange made of ceramics
- pressure vessel
- pressure vessel bag of rubber

Motor

- closed, chilled outside
- IPX4 protection
- insulation class F
- thermal protection in the motor winding
- speed 2850 rpm
- flexicable 1,5 m

Usage

- type of liquid: pure water without solid additives and abrasive material
- max. pumped liquid temperature 40°C
- max. working pressure 10 bar
- max. working pressure 6 bar

Aplikace

- small pressure devices
- Booster setst
- irrigation

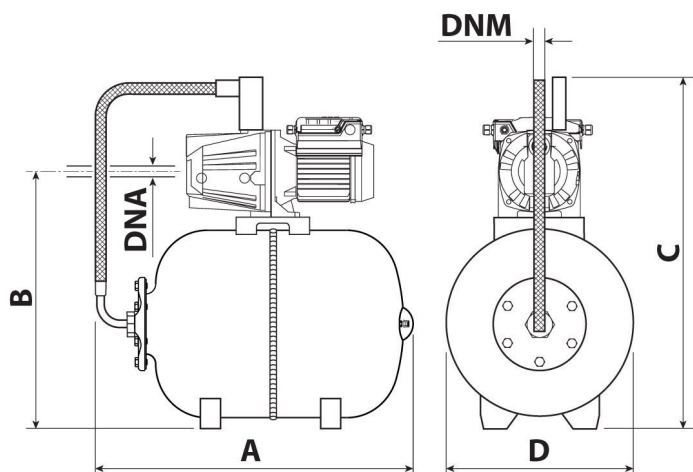

Type:	100
Power input:	1100 W
Q max:	6000 l/h
Head height:	48 m
Voltage:	400 V
Weight:	32 kg
A dimensions:	725 mm
B dimensions:	625 mm
C dimensions:	655 mm
D dimensions:	495 mm
DNA dimensions:	1"
DNM dimensions:	1"
Max. temperature:	40 °C
ON/OFF Pressure:	2 - 3,5 bar
Tank volume:	100 l
Suction height:	7 m
Max. over pressure:	6 bar