

Underground horizontal polyethylene tanks are designed for clean or service water or as waste pits. They are not intended for surface installation. Their biggest advantage is the installation without the need for concreting (they are installed directly into the excavation).



Construction characteristic

- made of high-density non-toxic linear polyethylene
- have a monolithic construction without critical points

Usage

- they are designed for clean or service water or as waste pits

Accessory

- the tank is supplied with the top lid
- part of the delivery is proof of impermeability

Technical parameters

- are resistant to UV radiation, algae formation, temperature fluctuations, impact and chemicals
- resistant to temperatures up to 60°C
- they can be easily cleaned with conventional cleaning agents
- they are light, storable and easy to handle
- not intended for surface installation
- the advantage is the installation without the necessity of concreting (we install directly into the excavation)
- the inspection holes have a standard height of 30 cm

Installation instructions

- Install a maximum of 80 cm below the earth's surface, the trench for the tank must be 20 cm larger than the container itself.
- Place the container in a horizontal position and into a 10 cm layer of tamped sand
- If installing in conditions where groundwater is or threatened with tree roots, we recommend installing it on a concrete foundation and encircling the walls.

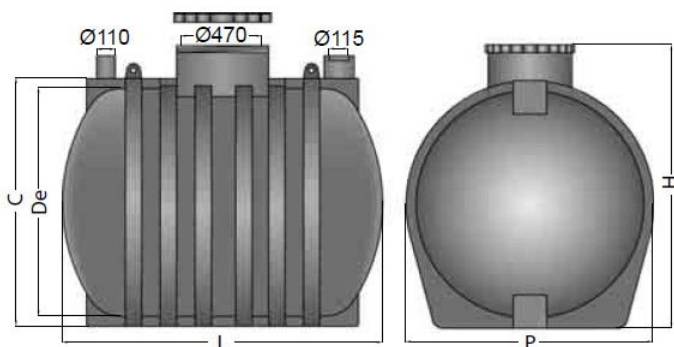

| | |
|-------------------------------|---------|
| Type: | HZ 1500 |
| Weight: | 100 kg |
| L dimensions - length: | 1570 mm |
| H dimensions - height: | 1445 mm |
| De: | 1200 mm |
| P: | 1310 mm |
| C dimensions: | 1250 mm |
| Tank volume: | 1500 l |
| Inlet size: | 470 mm |

