

Booster sets suitable for pumping clean water without solid impurities and abrasive material.

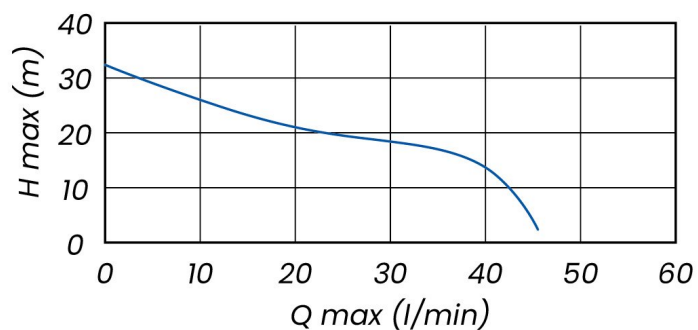

Construction characteristic

- cast iron pump body
- technopolymer impeller
- Stainless steel shaft
- a mechanical seal made of graphite and a counterflange made of ceramics
- pressure vessel bag of rubber

Motor

- closed, chilled outside
- IPX4 protection
- insulation class F
- single phase version with permanently built-in condenser
- thermal protection in the motor winding
- speed 2850 rpm
- flexicable 1,5 m

Usage

- type of liquid: pure water without solid additives and abrasive material
- max. pumped liquid temperature 40°C
- max. recommended suction height with non-return valve 8 m
- max. working pressure 4 bar

Aplikace

- small pressure devices
- Booster setst
- irrigation

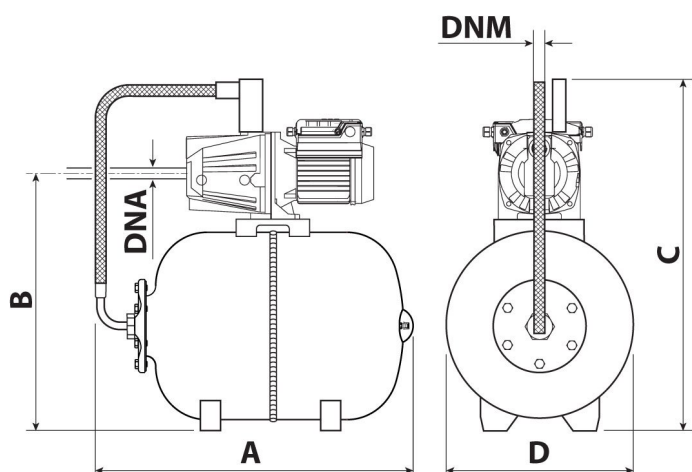

Type:	18
Power input:	600 W
Q max:	l/h
Head high:	32 m
Voltage:	230 V
Weight:	18 kg
A dimensions:	560 mm
B dimensions:	420 mm
C dimensions:	640 mm
D dimensions:	280 mm
DNA dimensions:	1"
DNM dimensions:	1"
Max. temperature:	35 °C
ON/OFF Pressure:	1,4 - 2,8 bar
Tank volume:	18 l
Suction height:	8 m
Max. over pressure:	6 bar

